

Box Scrapers

BB12 Series

	BB1248	BB1260	BB1272
Working Width	48"	60"	72"
Capacity	9.4 cu. ft.	11.75 cu. ft.	14.1 cu. ft.
Weight	316 lbs.	360 lbs.	404 lbs.
Number of Shanks	4	4	6
Shank Material	3/4" x 2 1/2" x 15" heat treated spring steel		
Vertical Shank Positions	3- positions (2 1/4" above scraper end plates; 1/4" and 2 3/4" below scraper end plates)		
Shank Tip Construction	Replaceable heat treated dimpled-on tips		
Shank Beam	4" x 4" x 1/4" Manufactured shank tube		
Shank Lift Mechanism	Manual lift with spring retainer at each shank		
Moldboard	Bumped-formed moldboard 15 3/8" vertical height		
Side Panels	3/16" thick x 16" high x 24" deep		
Depth of Bucket	23 1/8"		
Bucket Reinforcement	Two welded braces to rear of bucket		
Cutting Blades	2 ea. 3/8" x 6" high carbon, heat treated cutting edges; reversible and replaceable		
Maximum H.P. Rating	30 Hp		
A-Frame Material	1/2" x 3"		
3-Point Hitch Type	Double strap lower hitch Cat. I (Fits Land Pride Quick Hitch)		

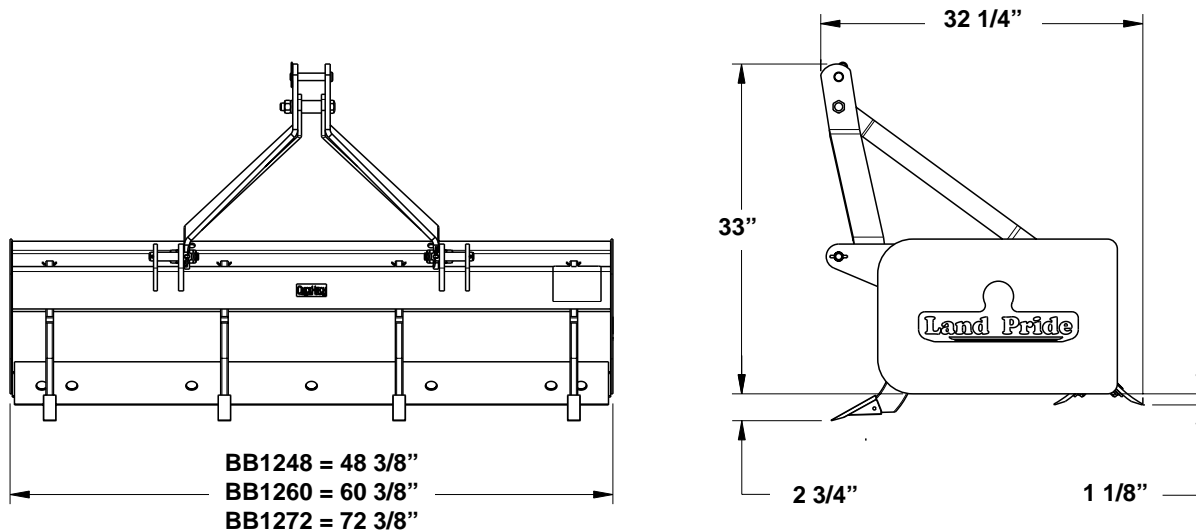

30737

Designs, specifications, features and information are subject to change without notice.